

SWYC 2019 Sailing Instructions (As of 5/15/2019)
(There are no changes from last year)

Sailing will be under the current US SAIL Racing Rules **2017-2020**, INCLUDING the starting sequence, which will be as follows:

Untimed before Start R/C **MAY** sound several Sound Signals shortly before the Warning Signal

(0:00) 5 Min. to Start **WARNING Signal** – Class flag Up & 1 Sound Signal

(1:00) 4 Min. to Start **PREPARATORY Signal**
"P" Flag (Blue w/ white center) Up &
Sound Signal (Class Flag Also Stays Up)

(4:00) 1 Min. to Start "P" Flag Down & 1 **LONG** Sound Signal
(Class Flag Stays Up)

(5:00) **Start** Class Flag Down & 1 Sound Signal - **Next Class flag (or red flag)** Up

**Life Jackets
Must Be
Worn**

If a next Class flag goes up, it represents the warning (5 Min.) signal for that Class/Fleet. A red flag will be displayed after the last Class start and will remain up until the last boat still racing has finished.

Note that sound signals are advisory only and visual flag signals are governing.

Other flag signals that may be used are as follows:

R/C Flag (Large blue rectangular flag with white "RC" and red fouled anchor) - When up, this is one end of the Start/Finish line.

Class Flags: Pelicans (Rectangular white flag with red Pelican insignia) - Boats with DP-N greater than 105 start with Pelicans. (Slow Boat Fleet) **Lasers** - Large rectangular white flag with red Laser insignia. Boats with DP-N less than or equal to 105 start with Lasers. (Fast Boat Fleet)

Answering/Postponement Pennant (Red and white vertical stripes) – The Answering/Postponement Pennant will be accompanied by 2 sound signals when raised and 1 sound signal when removed. **Postponement** Note: WARNING Signal (5 Min. to Start) will be approximately 1 minute after postponement flag is removed.

Individual Recall Flag ("X" Flag - White with blue cross) – One or more boats over early. **Individual Recall Flag** will be accompanied by one sound signal and attempts will be made to verbally notify premature starters.

General Recall / First Substitute (Blue pennant with yellow center) – Race will be restarted. WARNING Signal (5 minute start sequence starts approximately 1 minute after **General Recall / First Substitute** is lowered. **General Recall / First Substitute** will be accompanied by two sound signals when raised and one sound signal when lowered.

Shortened Course Flag ("S" Flag - White with blue square in middle) – The course is shortened. When displayed at a mark, that mark becomes the new finish mark.

Abandoned Race Flag ("N" Flag (Blue and white checks) – Follow R/C boat and return to starting area and await start of a new race or return to launching area.

Courses will be per SWYC Course Numbering System and will be POSTED on the Committee Boat Prior to Each Race. Different classes may be sent on different courses. Be alert for course changes up until the Prep signal for your Fleet. Courses and the course numbering is detailed on page 2.

Other courses may be established by verbal instructions from the race committee. Sail close by the R/C prior to the starting sequence to observe course number or receive other instructions.

De-confliction of Fleets: During the period from any Fleet PREPARATORY signal until that Fleet STARTING signal, boats of all other Fleets are to keep clear of the Starting Area unless they are already racing or clearing the area after finishing. The Starting Area is defined as a box 100 feet ahead of and behind the start line and 200 feet beyond both ends of the start line. If reasonably possible, a boat that is not racing shall not interfere with a boat that is racing (Rule 23.1). A boat is considered racing from its PREPARATORY signal until it has finished and cleared the finish line. As a matter of courtesy, boats in classes not competing for trophies are requested to avoid impeding boats from classes that are competing for trophies. This de-confliction section does not supersede any of the rules of Part 2-“When Boats Meet”.

360 degree penalties apply for ALL rules of part 2 or rule 31 infractions. This modifies rule 44.1.

A **closed** start/finish line meets the definition of an obstruction, and therefore shall be considered such with Rule 19.2 applicable.

Protests will hopefully be avoided. However, if a protest is lodged in accordance with all applicable provisions of the RRS, an attempt will be made to resolve the issue through consultation with the rules and the parties involved. If this is not possible, a properly constituted protest hearing will be scheduled at a later date.

Course 1 – Windward/Leeward

- **Once around.**
- **All marks to port.**
- **Start/finish line is closed.** Go around either end on the down wind leg or upwind if continuing on to an additional lap.
- If two windward marks are set, the Fast Boat Fleet sails to the more distant mark, and the Slow Boat Fleet sails to the closer mark.

Possible Fast Boat Windward Mark

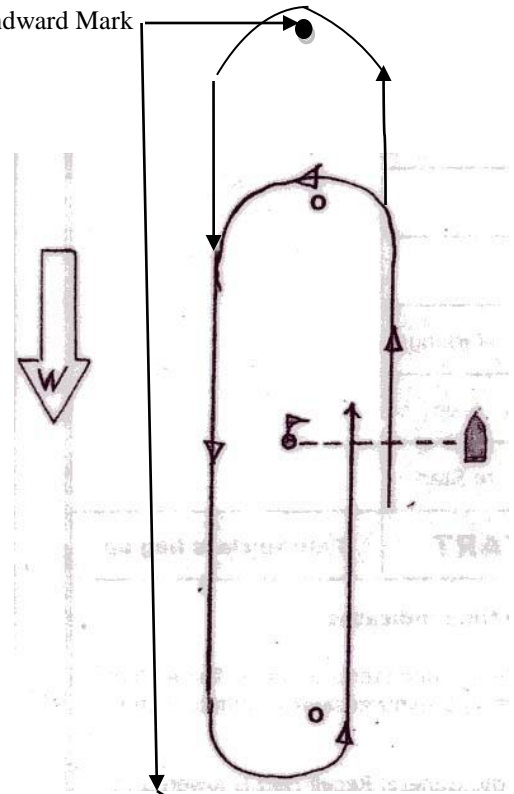

Course 2 – Triangle

- **Once around.**
- **All marks to port.**
- **Start/finish line is closed.** Go around either end if continuing on to an additional lap.
- If two windward marks are set, the Fast Boat Fleet sails to the more distant mark, and the Slow Boat Fleet sails to the closer mark

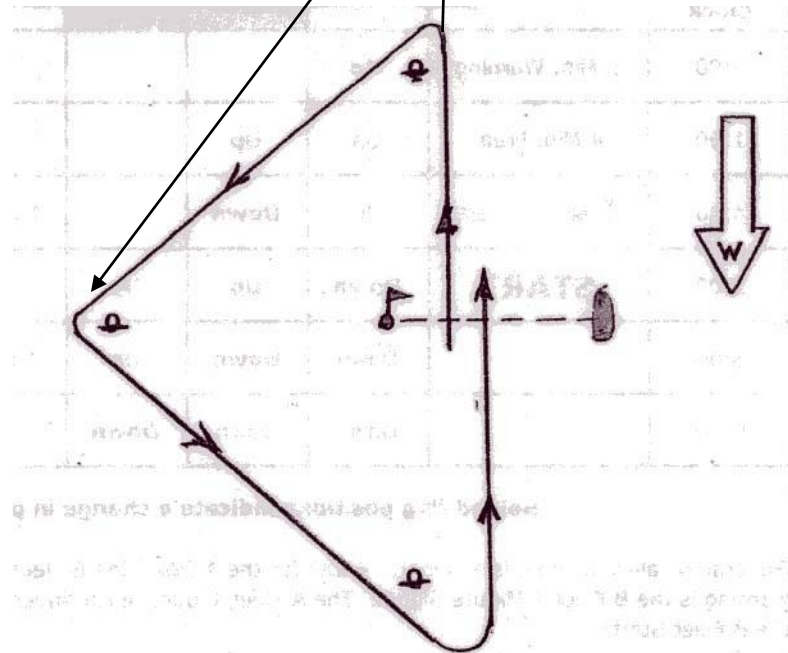

Combinations:

- Course 11 - Two consecutive windward/leeward laps
- Course 12 - Windward/leeward followed by triangle
- Course 21 - Triangle followed by windward/leeward
- Course 22 - Two consecutive Triangles
- Course 211 - Triangle followed by two windward/leeward laps
- Course 221 - Two Triangles followed by a windward/leeward
- Course 0 – (No Numbers Displayed) Windward/Finish Leave windward mark to port and finish downwind